

# MOVI 100



Innova's Movi is the electronic horizontal professional batch freezer of the latest generation: a functional, practical, robust and reliable work tool. Innova's patented blade ensures absolute hygiene inside the cylinder, a perfect creamy mixture and complete extraction of the ice cream at the end of each work cycle. Movi is equipped with highly efficient motors to ensure the lowest amount of energy consumption in full respect of the environment.

**INNOVA IS THE FIRST ITALIAN GELATO PRODUCER TO OFFER**

**5 YEARS WARRANTY**

## PRODUCTION

The machine serves cream based gelato, fruit based gelato and Italian slush.

## CAPACITY

From 6lt. to 13lt. of mix / cycle  
From 45kg to 100kg/h of gelato

## ELECTRONIC CONTROL

The freezing cycle is automatic and the machine detects automatically the consistency of the product.

The user just sets the desired consistency parameter. The machine detects automatically the quantity of mix and stops automatically to avoid production errors; The machine is equipped with 1 Inverter on the blade to grant several automatic rotation speeds.

## COOLING SYSTEM

Water Cooling and Air Cooling available.



AISI 304 stainless steel  
14mm Door AISI 304 stainless steel  
Internal structure.



Patented FEMALE blade system -  
MALE cylinder  
Self-expanding knives - NO SCREWS and NO SPRINGS.



Gear motor IE3 - Premium efficiency energy class  
Powered by inverter - NO BELTS.



User Friendly Water Proof keyboard and LCD display for selection of the desired program.



N. 1 Inverter on the blade to grant several automatic rotation speeds.



Simplified cleaning procedures with the MALE Cylinder System The cylinder can be completely emptied without any waste during extraction.

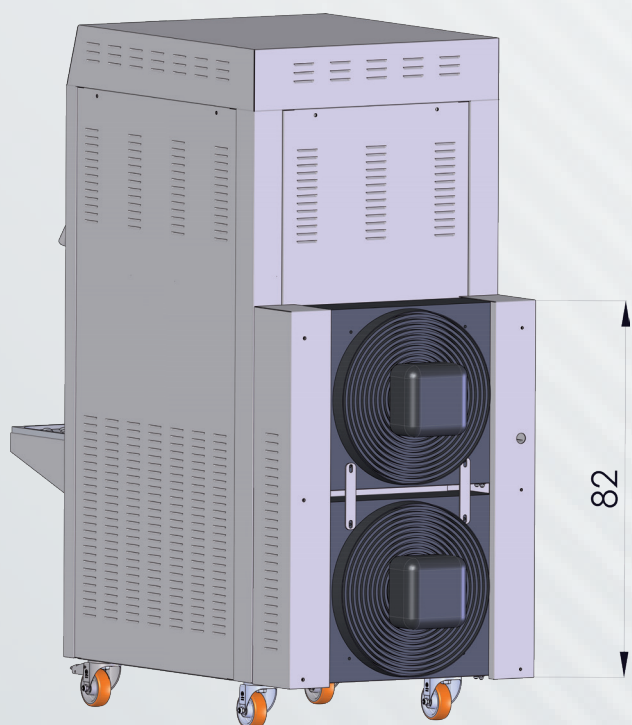
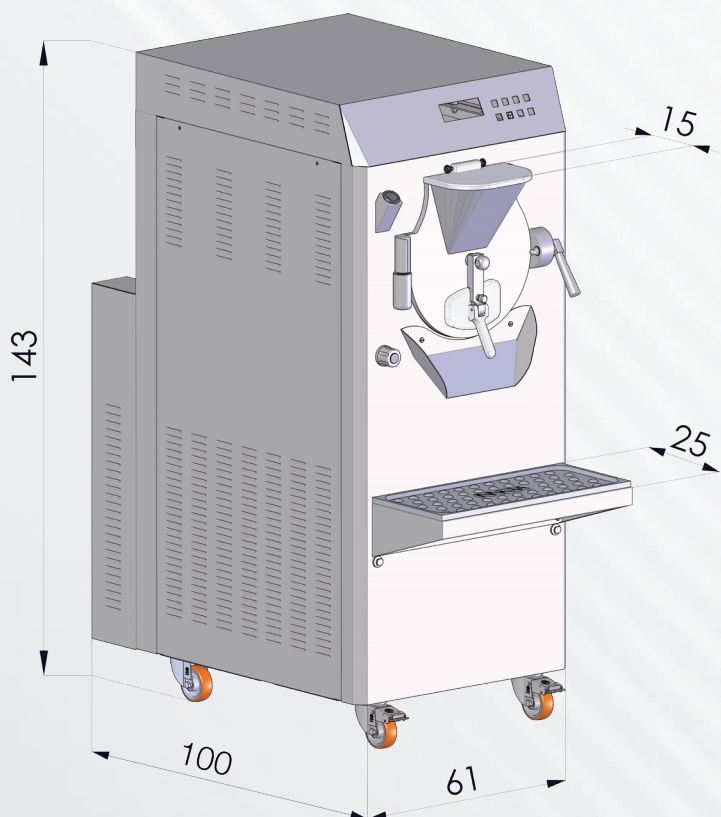

**Power source** 400/50/3

**Power** 7.5kw

**Condensation** Water or Air cooling

**Hourly Prod.** 45-100 kg

**Load cycle** 6 - 13 lt

**Width** 143 cm

**Depth** 123 (+10) cm

**Height** 143 cm

**Weight** 310 kg

**Product code** IN100MA01N

**Power supply** 3 x 400 VAC + N + PE / 50-60 Hz

**Marking** CE

**Gas** R 452 A

#### TECHNICAL SPECIFICATIONS

- 4 stainless steel wheels Ø80x3 - brake on front wheels, turning back wheels;
- Integrated shower with safety electrovalve and separated connection;
- The machine keeps the ready gelato conserved at the best quality for 20 minutes;
- Ejection mode includes the possibility to restart multiple times the compressor;
- Semi hermetic FRASCOLD compressor with protection;
- LAN connection cable for RCS - REMOTE CONTROL SYSTEM;
- Self-expandible scrapers without springs or screws;
- 15 Fruit Gelato Consistency levels, 15 Cream Gelato consistency levels, Slush Program, Washing Program, Ejection Mode;
- Female Blade - male Cylinder System.

